

Aldeck Telescopic Handrail System Installation Guide

*Compliance Testing to
AS/NZS 4994.1:2009*

Patented

CONTENTS	PAGE
Introduction	2
Aldeck Safety System Components	
<i>Components in Aldeck Safety System</i>	3-4
Installation of Telescopic System	
(A) <i>Telescopic System</i>	5-7
Order and Returns Form	8

Introduction

The Victorian occupational health and safety act 2004 requires for all people and organizations to ensure a safe and healthy work environment. The Occupational Health and safety (prevention of falls) National code of practice 2008, provides practical guidance to all duty holders related to fall hazards associated with construction work and requires all duty holders to identify all risks that involve the possibility of someone falling more than 2 metres and eliminate all such hazards ,so far as is reasonably practical.

It is also noted in the code that a fall from almost any height including falls from below 2m can result in serious injury or death .It is possible that a number of factors can combine to create a dangerous situation making the hazard identification and risk assessment process essential for work at any height.



An employer's primary duty of care is to eliminate the risk of injury to an employee. The best way of achieving this is before work commences, identifying potential risks and applying risk control measures as set out in the hierarchy of control matrix of the prevention of falls compliance code. The use of perimeter guardrail is in the second highest control measure available, along with safety mesh and elevated work platforms. Only the possibility of carrying out work on the ground rates higher in the hierarchy than using a perimeter guardrail system. Aldecks handrail system can be used pre, during or post construction to minimize the risk of people falling from height. The Aldeck handrail system is fully tested and complies with AS 1657-2013 and AS/NZS 4994.1:2009

- The Aldeck handrail system should be erected and dismantled in accordance with legislation under the OH&S act. A thorough risk assessment should be conducted and a safe work procedure applied.
- The handrail system should only be installed, modified or dismantled by a competent person familiar with the Aldeck safety rail system.
- Posts to be installed at a maximum of 3000mm.
Handrail heights are dictated by the Australian standard and are dependant on the structure pitch.
- Where midrails are used, the nominal clear distance between rails shall not exceed 450mm.
- The nominal clear distance between a midrail and a toeboard or bottom rail shall not exceed 275mm. In any section of edge protection, the rails shall be nominally parallel.

IMPORTANT

It is important that the structure to which the temporary edge protection is to be attached can support the forces that may be applied when the edge protection restrains a person from falling from the edge.

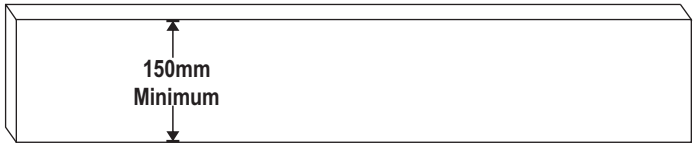
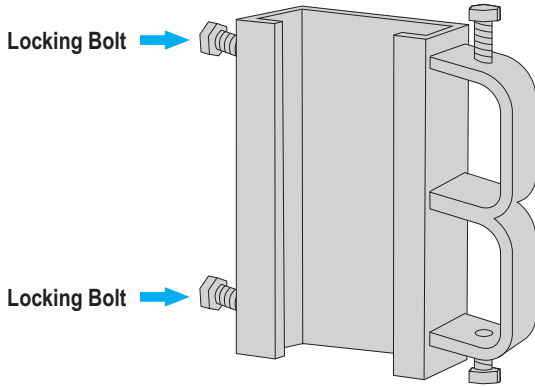
Aldeck Safety Rail Components			
Part No.	Description	Part No.	Description
1	Base Post 1100mm Application Used as perimeter edge protection on concrete slabs or timber form work	2	Extension Post Application Used to extend Base Post from 1.1m anywhere up to 2.4m
Picture / Diagram		Picture / Diagram	
<p>Upper Rail Loop →</p> <p>Lower Rail Loop →</p> <p>Upper Rail Loop →</p> <p>Lower Rail Loop →</p> <p>Upper Rail Loop →</p> <p>Lower Rail Loop →</p> <p>Locking Bolt ←</p> <p>Locking Bolt ←</p> <p>Through bolt location for 2.4m high post →</p> <p>Through bolt location for 2m high post →</p>		<p>Upper Rail Loop →</p> <p>Lower Rail Loop →</p> <p>Upper Rail Loop →</p> <p>Lower Rail Loop →</p>	

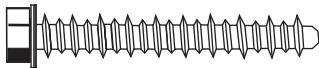
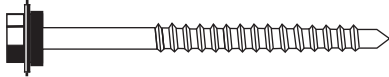
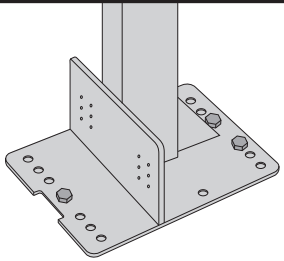
Aldeck Safety Rail Components		
Part No.	Description	Picture / Diagram
3	Kick Board	 <p>150mm Minimum</p>
4	Detachable Rail Bracket Application Used as additional rail holder when extension post is extended above 2000mm	 <p>Locking Bolt →</p> <p>Locking Bolt →</p>
5	Handrail 38mm x 25mm x 2mm 3200mm Length	
6	Screw 14 Gauge Concrete	 <p>(4) minimum 8mm x 60mm long screw bolts per post.</p>
7	Screw 14 Gauge Timber Timber 90mm	  <p>(3) minimum 14mm x 90mm type 17 timber screws per post.</p>

INSTALLATION GUIDE

Telescopic Handrail System

Aldeck

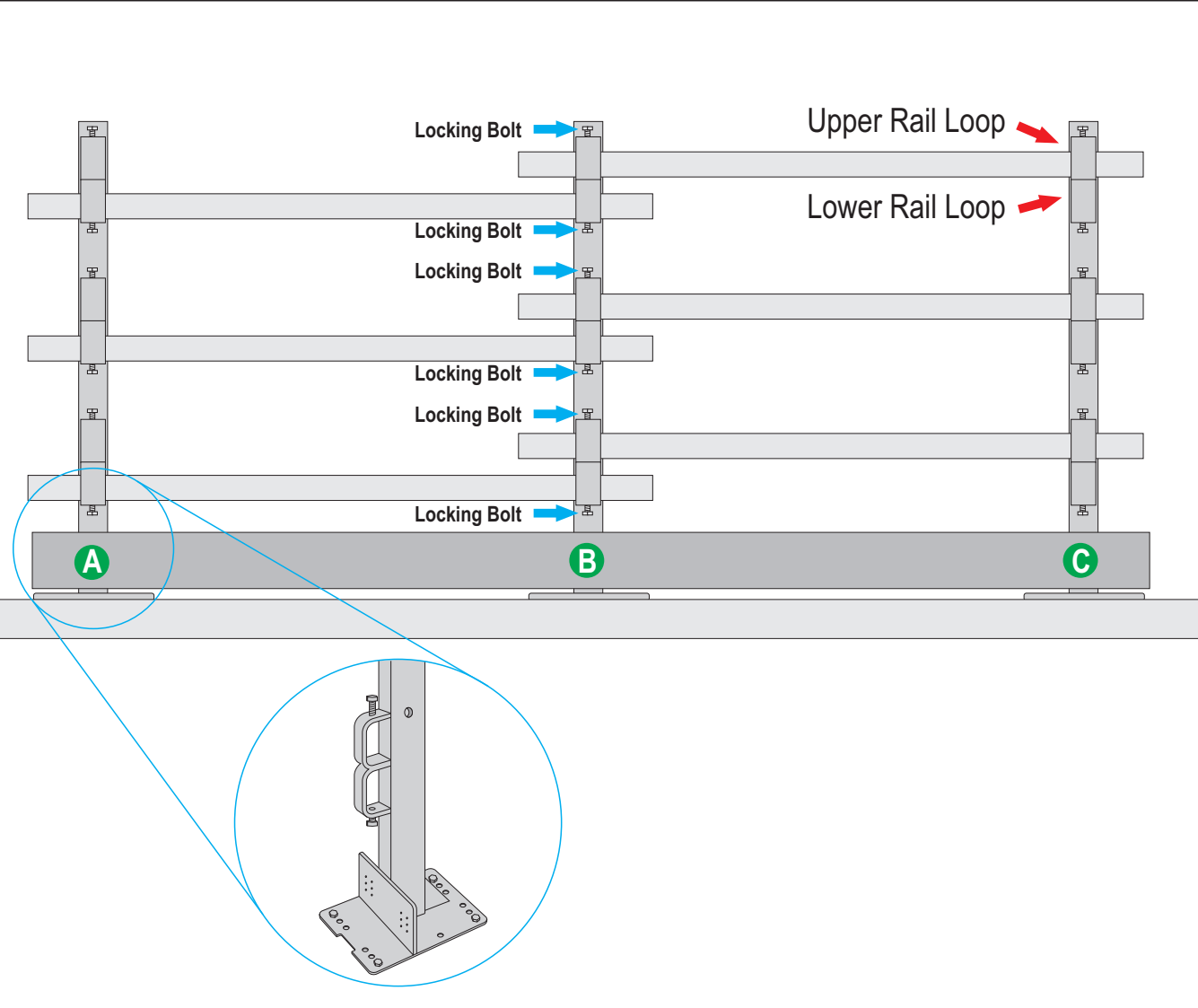

Locking Bolt →

Upper Rail Loop →

Lower Rail Loop →

Locking Bolt →

Locking Bolt →

Locking Bolt →

Locking Bolt →

Locking Bolt →

A **B** **C**

STEP 1 Position the First Base Post **A** (Part 1) into desired location and fix to structure using appropriate fixings. Minimum of (4) 8mm screw bolts per post (Concrete) or (3) 14 x 90mm timber screws per post (Timber). Timber screws must go through plywood and into timber support beams.

STEP 2 Position the next Base Post **B** in the desired location, no more than 3 metres apart. Install rails placing them consistently down the base posts in either the top or bottom rail loop for any one segment. It is important that each rail is placed in the corresponding Upper or lower rail loop. Lock rails into position using the lock bolts supplied in each rail loop.

STEP 3 Position Base Post **C** in the desired location, no more than 3 metres apart. Install rails placing them consistently down the base posts in alternate rail loops than the preceding set of rails.

Repeat these 3 steps until the entire area you require has hand rail installed.

INSTALLATION GUIDE

Telescopic Handrail System

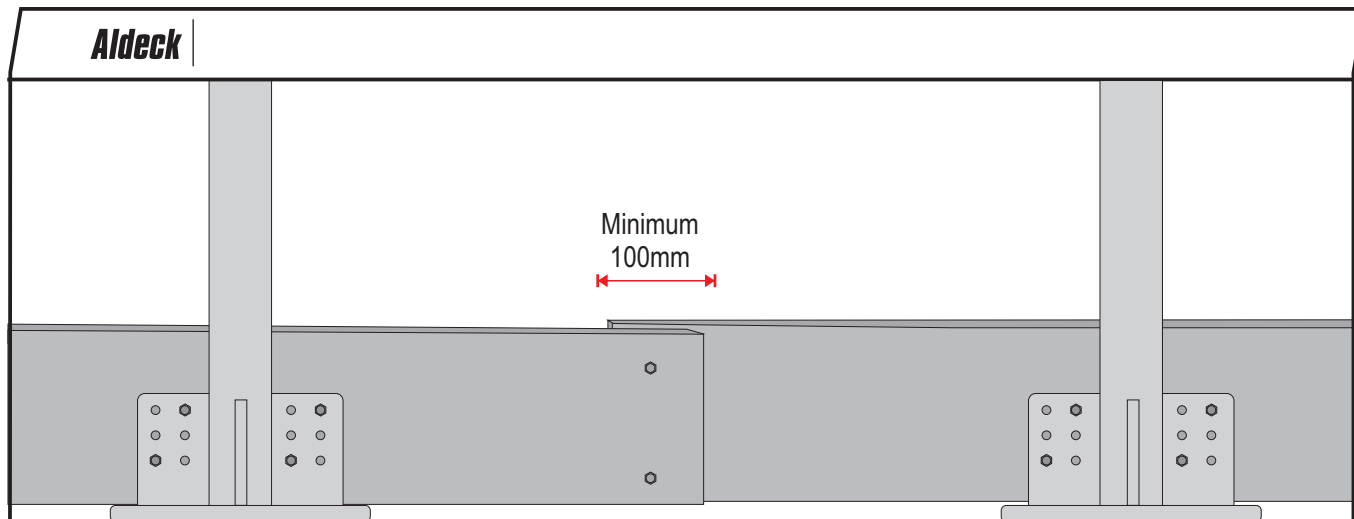

STEP 4 Attach Kickboard with a minimum of 4 screws per post. If the Kick boards overlap at a point other than on the Base Posts there should be a minimum of 100mm overlap with a minimum of 2 screws installed in the overlap to hold the kickboards together.

STEP 5

For higher rails place the Extension Post into the Base Post. Lock into place using the Locking Bolts provided in the Base Post.

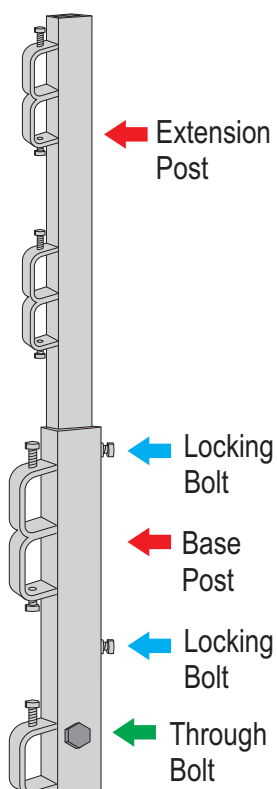

A through bolt is provided in each Base Post to prevent the Extension Post from being able to collapse in the Base Post. This bolt needs to be moved to the higher location if the handrail is extended from 2m to 2.4m high.

STEP 6

For rails above 2 metres place Detachable Rail Bracket onto the Extension Post. Space evenly between the rail loops above and below.

Lock into position with lock bolt supplied in each bracket.

Gap between rails must not exceed 450mm.

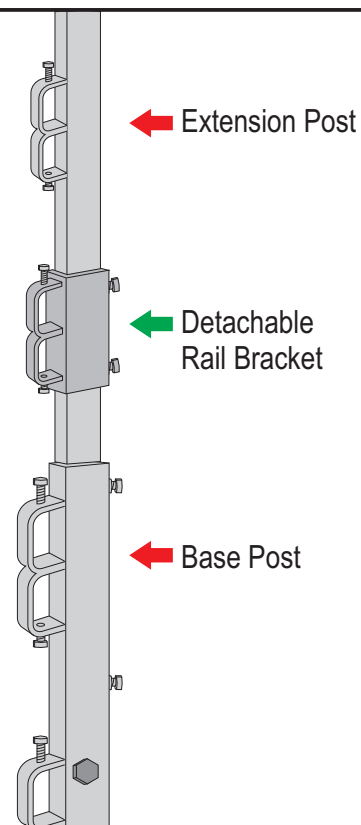

INSTALLATION GUIDE

Telescopic Handrail System

Aldeck

- Maximum post spacing is 3 metres.
- Rails may not exceed 600mm overhang from post
- When installing or dismantling, this work must be in accordance with state legislation under the OH&S act.

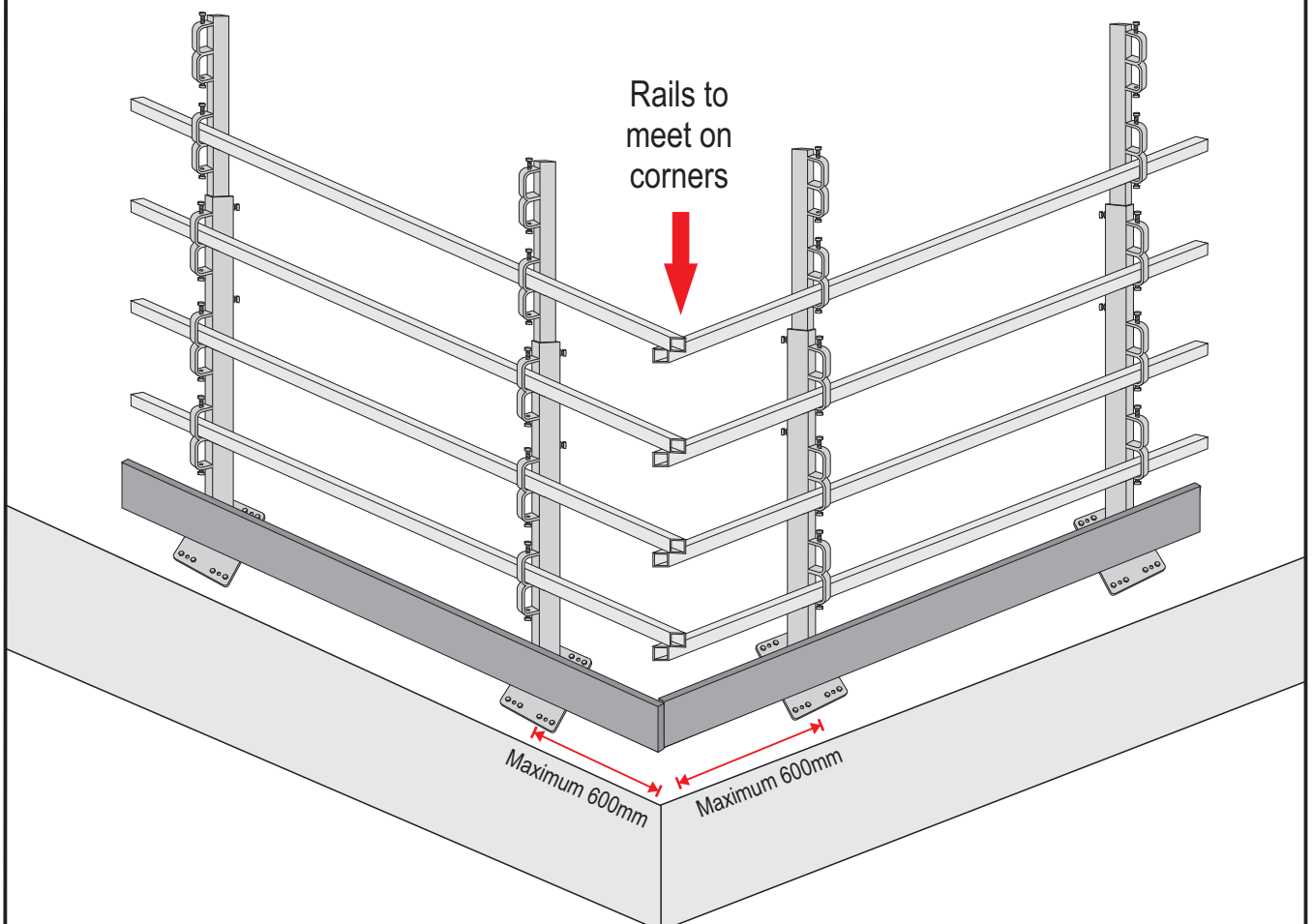



HANDRAIL ORDER FORM

15 Brock Street, Thomastown VIC 3074 Tel: (03) 9465 1122 Email: aldeck@aldeck.com.au www.aldeck.com.au

Company: _____ Order No.: _____

Job Name: _____

Address: _____

Contact on site: _____ Tel: _____

Delivery Fee YES NO

Date Required: _____

TELESCOPIC SYSTEM		HIRE	COMMENTS
Code #	Description	Quantity	
1	Base Post 1100mm		
2	Extension Post		
3	Kick Board		
4	Detachable Rail Bracket		
5	Handrail 3200mm Length		
6	Screw 14 Gauge Concrete		
7	Screw 14 Gauge Timber 90mm		

Received by: _____ Date: _____

Signing this form confirms acceptance of Aldeck Group terms and conditions of Hire as listed on our website www.aldeck.com.au

HANDRAIL RETURNS FORM

Company: _____

Job Name: _____

Address: _____

Contact on site: _____ Tel: _____

Pick Up Fee YES NO

Date Returned: _____

TELESCOPIC SYSTEM		RETURN	COMMENTS
Code #	Description	Quantity	
1	Base Post 1100mm		
2	Extension Post		
3	Kick Board		
4	Detachable Rail Bracket		
5	Handrail 3200mm Length		
6	Screw 14 Gauge Concrete		
7	Screw 14 Gauge Timber 90mm		

Returned by: _____ Date: _____

Signing this form confirms acceptance of Aldeck Group terms and conditions of Hire as listed on our website www.aldeck.com.au